

geniumSchwank

Worldwide First Hydrogen
Industrial Heater

As a multinational family business, Schwank offers customised complete solutions for commercial and industrial HVAC systems.

For 90 years we have been a renowned leader of energy efficient solutions.



geniumSchwank – Shaping the Future with Hydrogen

Quality combined with maximum efficiency continues to be our passion. After 5 years of development, we are proud to present to you geniumSchwank, the world's first 100% hydrogen industrial heater. Fitted with a unique, patented burner design, this industrial heater features a one-of-a-kind hybrid multi-gas approach. This cutting-edge technology offers planning security for investors and owners alike, especially during the transition period from fossil fuel to renewable energy.

100% Natural Gas Today, 100% Hydrogen Tomorrow

While the supply of hydrogen may not be available instantly, geniumSchwank can firstly use natural gas or LPG. geniumSchwank can be easily adapted to hydrogen with just a few simple adjustments and calibrations. Other solutions in the market can only operate with a maximum of 20% hydrogen contents. geniumSchwank offers thus a sustainable, long-term planning security that no other industrial heating system can provide.

Smart, Sustainable, Schwank

As the global market leader for infrared industrial heating and as a dependable provider of HVAC systems, we strive for constant innovation. We provide climate neutral solutions for commercial and industrial applications – from singular heaters to complex turnkey solutions, including a complete Building Management Systems.

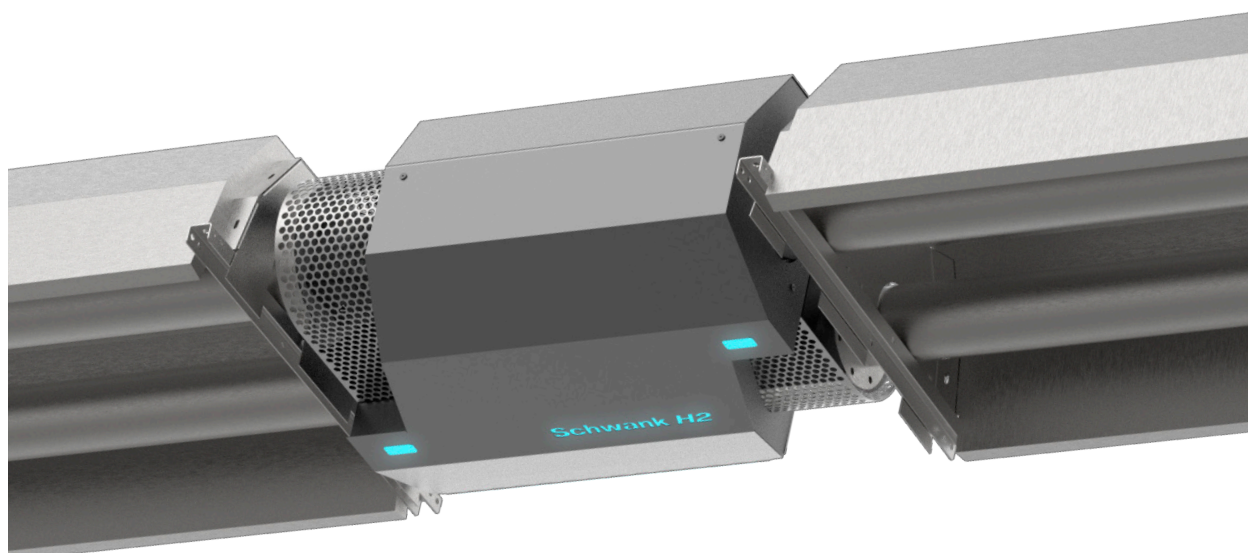

MADE IN GERMANY

The Future of Industrial Heating is Now

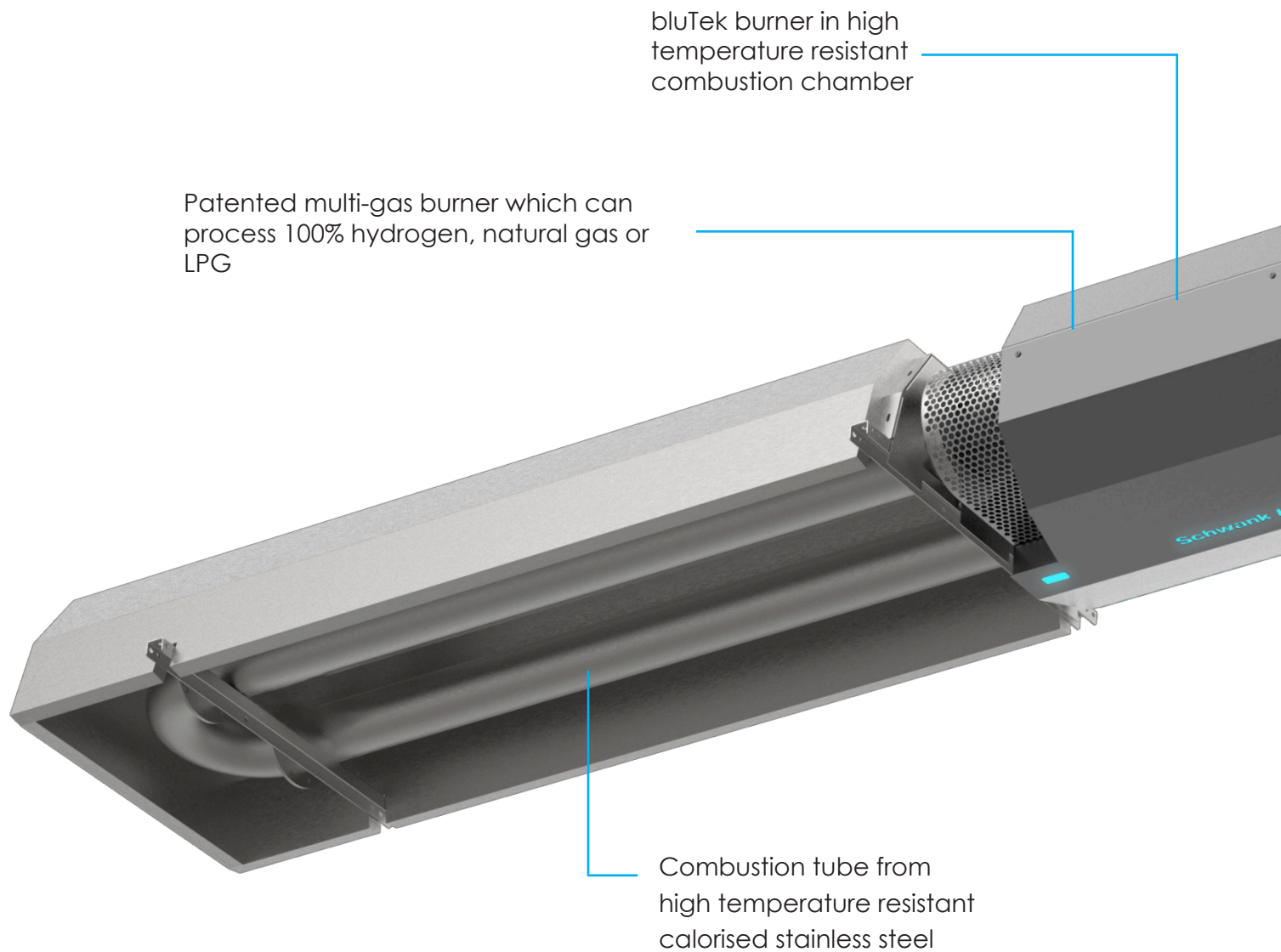

**New. 100%
Hydrogen.**



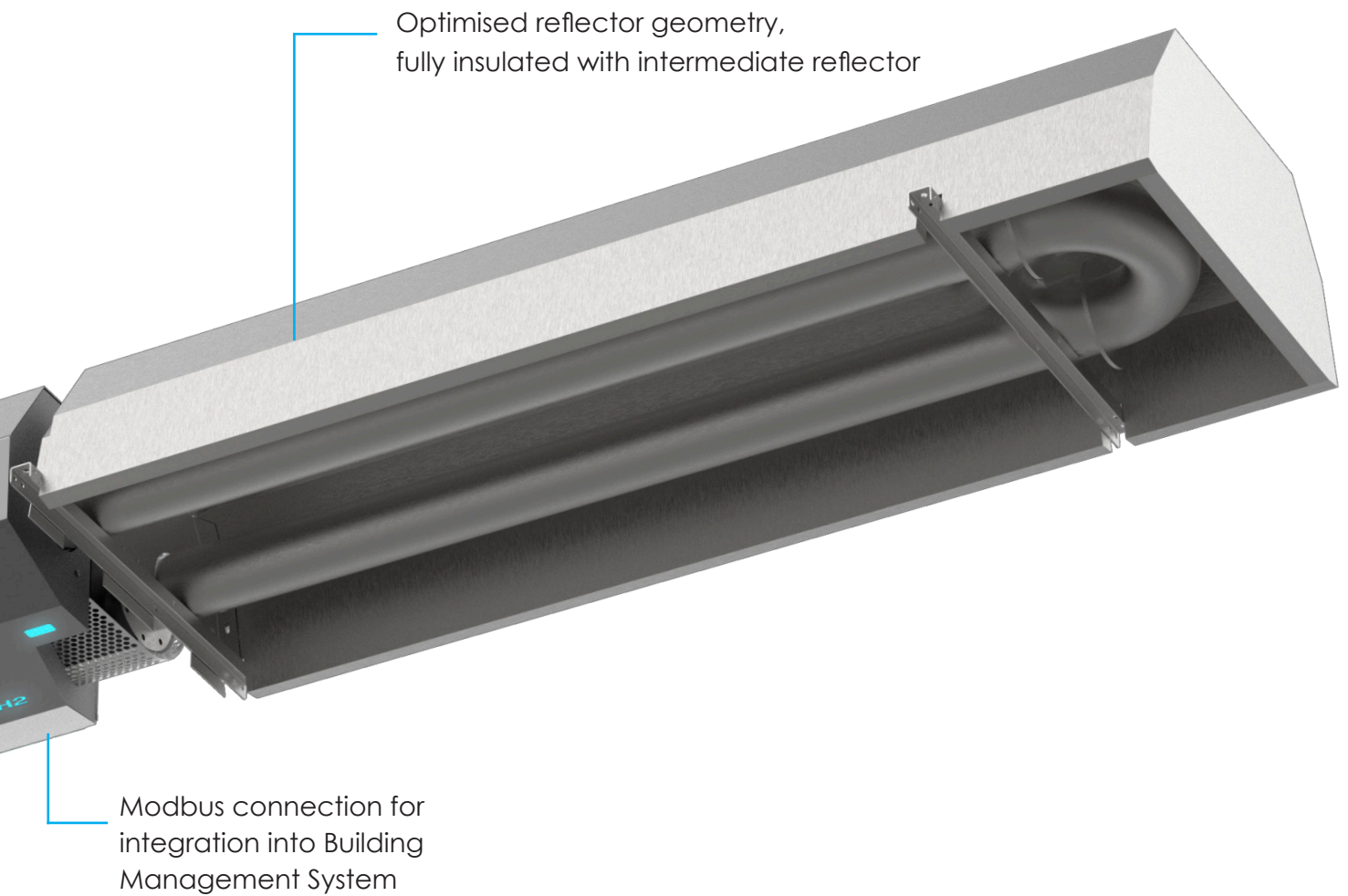

Revolutionising Infrared Heating

This efficient and reliable technology of infrared heating revolutionises the heating of industrial buildings. Heating is no longer just an accessory of a building, but an integral component of sustainability and energy flow management. Through a long-term investment in climate neutrality (CO₂ free), renewable energies, and flexibility, it is geniumSchwank which is at the forefront of green heating technologies. geniumSchwank comes in power ranges from 15 kW to 57 kW and in lengths of 4 to 13 metres.

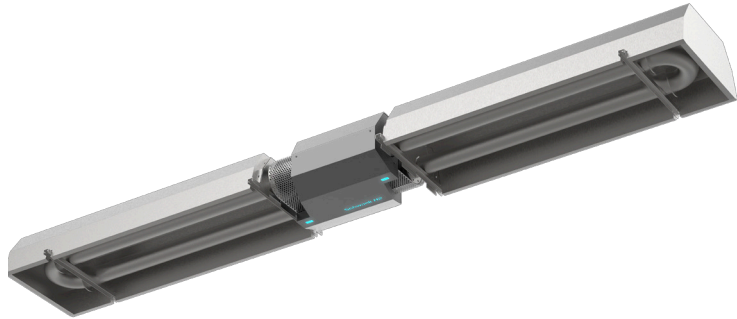

MADE IN GERMANY

Min. connection pressure

	15 - 57 kW
Natural Gas H	15 mbar
Natural Gas L	20 mbar
Propane	40 mbar
Hydrogen	40 mbar



Your Benefits:

- Multi-gas conversion: possibility of converting from fossil fuels (natural gas or LPG) to hydrogen
- Seasonal Efficiency of 99%*
- Highly reflective FERAN reflector
- Reflector housing completely insulated to minimise convection heat losses
- Unique reflector geometry (95% emissivity)
- Fully modulating: from 75% to 100% to adapt to seasonal heat loss
- ModBus capability for optimised controllability and connectivity

Technical Data

	315	320	630	635	950	960
Nominal heat load (kW), Hi	15,0	20,0	27,0	35,0	48,0	57,0
Minimum heat load (kW), Hi	11,5	15,0	20,5	26,5	36,0	43,0
Th. conductivity calorific value, Hi (%), max. load	94,3	93,6	94,8	93,1	93,9	93,1
Calorific value, Hs (%), partial load	96,1	95,5	96,0	95,3	95,6	95,4
Radiation factor, Hi (%), partial load	81,9	82,0	81,1	82,2	82,0	81,5
Radiation factor, Hi (%), nominal load	80,6	80,8	80,0	80,3	81,1	80,7
Seasonal Efficiency (%)	97,3	97,3	98,9	98,9	97,6	97,6

* measured according to DIN EN 416 at DVGW test laboratory on 635

Dimensions geniumSchwank 315/320

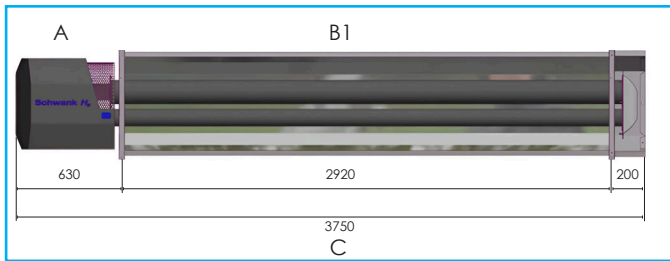

Dimensions geniumSchwank 630/635

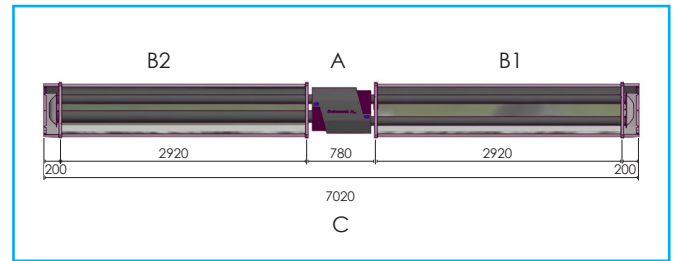

Dimensions geniumSchwank 950/960

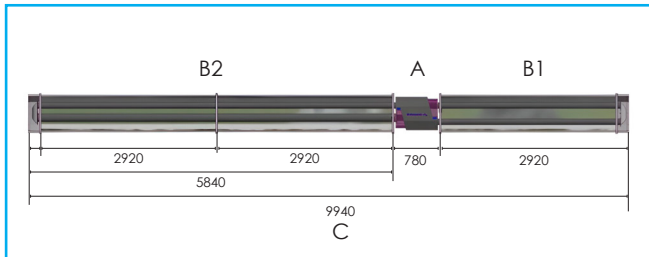

Dimensions geniumSchwank

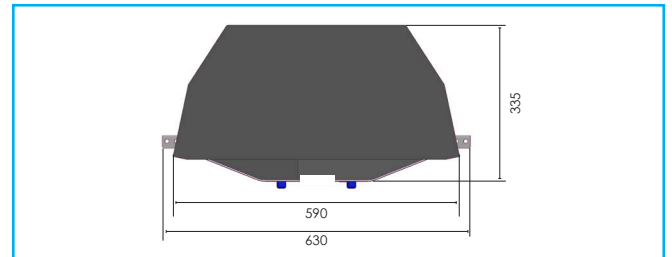

Dimensions	315	320	630	635	950	960
A (mm)	630		780		780	
B1 (mm)	2920		2920		2920	
B2 (mm)			2920		5840	
C (mm)	3750		7020		9940	
Weight (kg)	110		232		285	

	315	320	630	635	950	960
Nominal heat load (kW)	15,0	20,0	27,0	35,0	48,0	57,0
Gas consumption natural gas H / G 20 (m ³ /h)*	1,50	2,00	2,80	3,51	4,81	5,70
Gas consumption natural gas L / G 25 (m ³ /h)**	1,75	2,33	3,27	4,08	5,60	6,65
Gas consumption propane / G 31 (kg/h)***	1,17	1,56	2,18	2,72	3,73	4,43
Gas consumption hydrogen (m ³ /h)*****	5,0	6,7	9,0	11,7	16,0	19,0
Max. gas consumption (natural gas / propane / hydrogen)	60 mbar					
Flue gas connection (mm)	100					
Electric power consumption (W)	30,0	45,0	59,0	75,0	175,0	202,0
Protection class	IP 20					
Gas connection (external)	R 1/2"				R 3 /4"	
Electrical connection	230 V / Hz 50 ~					

Schwank Companies Worldwide



Germany - Headquarters

Schwank GmbH

Bremerhavener Str. 43 ■ 50735 Köln
Tel.: +49-221-7176 0
info@schwank.de
www.schwank.de

Austria

Schwank Ges.m.b.H.

Hetmanekgasse 1b/3 ■ 1230 Wien
Tel.: +43-1-609 1320
office@schwank.at
www.schwank.at

Benelux

Schwank BV

Vaart 7A ■ 4206 CC Gorinchem
Tel.: +31-183 766050
schwank@schwank.nl
www.schwank.nl

China

Schwank HVAC Technology (Tianjin) Ltd. Co.

7a Jimei Industrial Park
Devel. Area ■ 300385 Tianjin
Tel.: +86-22-87975319
info@schwank.cn
www.schwank.cn

Canada

Schwank Ltd.

5285 Bradco Blvd. ■ Mississauga,
Ontario, L4W 2A6
Tel.: +1-877-446 3727
csr@schwankgroup.com
www.schwankgroup.com

Czech Republic

Schwank CZ, s.r.o.

Nám. Republiky 1 ■ 614 00 Brno
Tel.: +420-545-211 530
info@schwank.cz
www.schwank.cz

Poland

Schwank Polska Sp. z o.o.

ul. Krańcowa 65 ■ 62-081 Przeźmierowo
Tel.: +48-32-201 05 58
info@schwank.pl
www.schwank.pl

Romania

Schwank SRL

bd. 9 Mai nr. 21 bl. B11/43-44 ■
610127 Piatra Neamt
Tel.: +40-233-22 69 66
schwank@schwank.ro
www.schwank.ro

Slovak Republic

Schwank s.r.o.

Vajnorská 100/B ■ 831 04 Bratislava
Tel.: +421-94-895 9535
info@schwank.sk
www.schwank.sk

United Kingdom

Schwank Ltd.

Unit D2, Armthorpe Business Park
Durham Lane ■ Doncaster DN3 3DY
Tel.: +44-20-8641 3900
sales@schwank.co.uk
www.schwank.co.uk

USA

Schwank USA, Inc.

2 Schwank Way ■ Waynesboro, GA 30830
Tel.: +1-877-446 3727
csr@schwankgroup.com
www.schwankgroup.com